

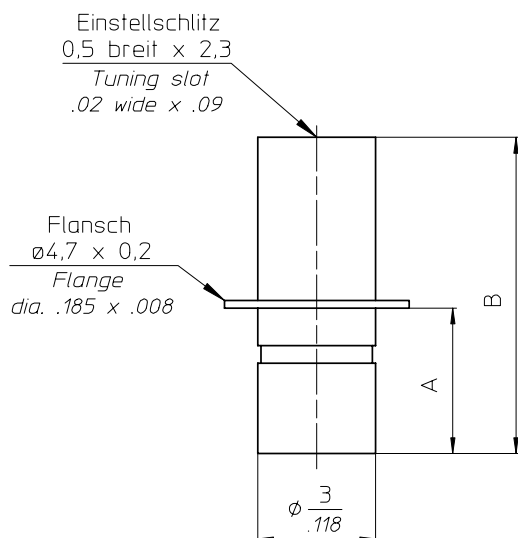

66-03.1... SAPHIRTRIMMER SAPPHIRE TRIMMER

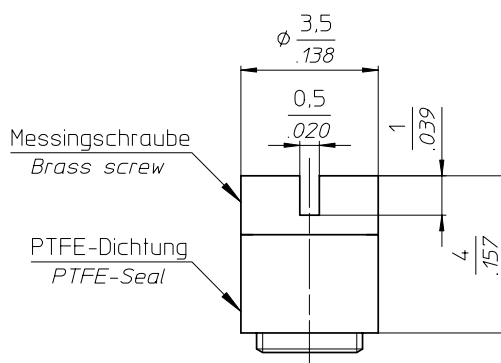

Zubehör/ Accessories



mehrmals verwendbare Montage-Dichtschaube
Seal cap suitable for repeated usage

TECHNISCHE MERKMALE UND DATEN / TECHNICAL DATA

EINSTELLDREHMOMENT <i>TUNING TORQUE</i>	0,1 - 1,0 Ncm <i>0.14 - 1.4 in.oz.</i>	LEBENSDAUER <i>ROTATIONAL LIFE</i>	≥ 75 Betätigungen, IEC 418 <i>≥ 75 cycles, IEC 418</i>
ANSCHLAGDREHMOMENT <i>STOP TORQUE</i>	max. 1,5 Ncm <i>max. 2.1 in.oz.</i>	VIBRATION <i>VIBRATION</i>	60 g / 10 - 2000 Hz <i>60 g / 10 - 2000 Hz</i>
BEFESTIGUNGSDREHMOMENT <i>MOUNTING TORQUE</i>	---	STOSSBEANSPRUCHUNG <i>SHOCK</i>	1500 g / 0,5 ms <i>1500 g / 0.5 ms</i>
EINSTELLGENAUIGKEIT <i>ADJUSTMENT ACCURACY</i>	≤ 1 x 10 ⁻³ vom Einstellwert <i>≤ 1 x 10⁻³ of adjusted value</i>	BETRIEBSTEMPERATUR <i>OPERATING TEMPERATURE</i>	-65°C ... +125°C <i>-65°C ... +125°C</i>
KONTAKTWIDERSTAND <i>CONTACT RESISTANCE</i>	< 0,001 Ω <i>< 0.001 Ω</i>	DIELEKTRIKUM <i>DIELECTRIC</i>	Saphir <i>Sapphire</i>

STANDARD - AUSFÜHRUNGEN / STANDARD CONFIGURATIONS

Teile - Nr. Part - No.	C _{min} [pF]	C _{max} [pF]	Prüfspannung Test Voltage [VDC]	Q-Faktor Q-Factor [@ 200MHz]	R _{isol.} R _{insul.} [MΩ]	TK _c [ppm/°C]	Maß A Dim.A [mm]	Maß B Dim.B [mm]	Gewicht Weight [ca. g]
66-0301-00002-000	0,4	2,5	1000	> 4000	> 10 ⁶	0 ± 50	2,3	5,8	0,26
66-0301-00004-000	0,6	4,5	1000	> 3000	> 10 ⁶	0 ± 50	3,7	8,0	0,34
66-0301-00008-000	0,8	8,0	1000	> 2000	> 10 ⁶	0 ± 75	6,5	12,3	0,49
66-0331-00002-000	0,4	2,5	1000	> 4000	> 10 ⁶	350 ± 75	2,3	5,8	0,26
66-0331-00004-000	0,6	4,5	1000	> 3000	> 10 ⁶	350 ± 75	3,7	8,0	0,34
66-0331-00008-000	0,8	8,0	1000	> 2000	> 10 ⁶	350 ± 75	6,5	12,3	0,49

SONDERAUSFÜHRUNGEN / SPECIAL CONFIGURATIONS

z.B. Trimmer unmagnetisch (Permeabilität < 1,001), verlängerte Welle u.a. auf Anfrage
e.g. Trimmer non-magnetic (Permeability < 1,001), extended shaft a.o. on inquiry