



TRONSER TRIMMER

for
professional
electronics

DATUM / DATE : 24.10.1991
ÄNDERUNG / REVISION : 10.04.2003

66-0312-00004-000

SAPHIRTRIMMER SAPPHIRE TRIMMER

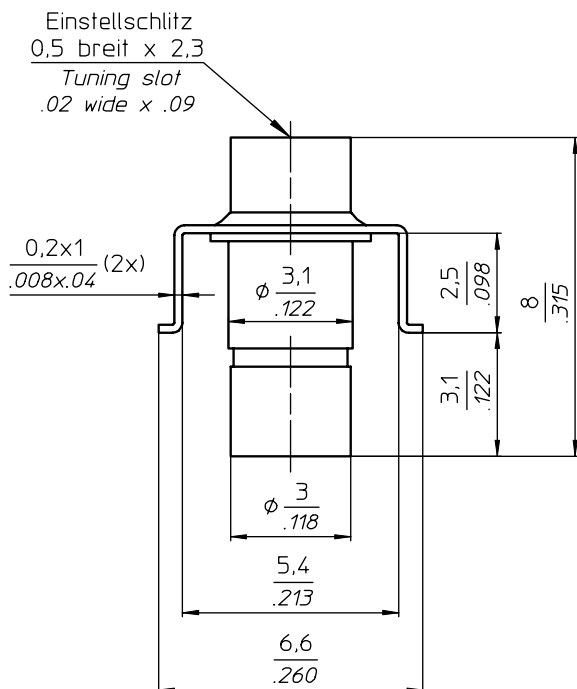

Zubehör / Accessories

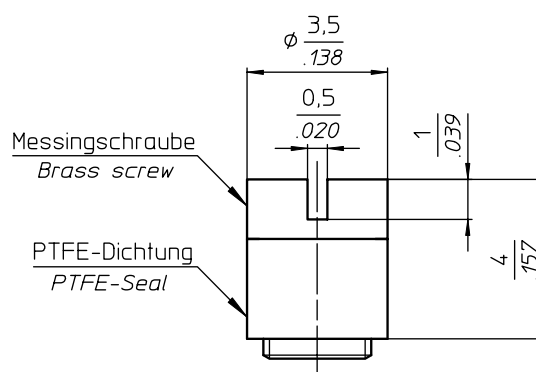

mehrmals verwendbare Montage-Dichtschaube
Seal cap suitable for repeated usage

TECHNISCHE MERKMALE UND DATEN / TECHNICAL DATA

EINSTELLDREHMOMENT TUNING TORQUE	0,1 - 1,0 Ncm 0.14 - 1.4 in.oz.	LEBENSDAUER ROTATIONAL LIFE	≥ 75 Betätigungen, IEC 418 ≥ 75 cycles, IEC 418
ANSCHLAGDREHMOMENT STOP TORQUE	max. 1,5 Ncm max. 2.1 in.oz.	VIBRATION VIBRATION	60 g / 10 - 2000 Hz 60 g / 10 - 2000 Hz
BEFESTIGUNGSDREHMOMENT MOUNTING TORQUE	---	STOSSBEANSPRUCHUNG SHOCK	1500 g / 0,5 ms 1500 g / 0.5 ms
EINSTELLGENAUIGKEIT ADJUSTMENT ACCURACY	≤ 1 x 10 ⁻³ vom Einstellwert ≤ 1 x 10 ⁻³ of adjusted value	BETRIEBSTEMPERATUR OPERATING TEMPERATURE	-65°C ... +125°C -65°C ... +125°C
KONTAKTWIDERSTAND CONTACT RESISTANCE	< 0,001 Ω < 0.001 Ω	DIELEKTRIKUM DIELECTRIC	Saphir Sapphire

STANDARD - AUSFÜHRUNGEN / STANDARD CONFIGURATIONS

Teile - Nr. Part - No.	C _{min} [pF]	C _{max} [pF]	Prüfspannung Test Voltage [VDC]	Q-Faktor Q-Factor [@ 200MHz]	R _{isol.} R _{insul.} [MΩ]	TK _c [ppm / °C]	Maß A Dim.A [mm]	Maß B Dim.B [mm]	Gewicht Weight [ca. G]
66-0312-00004-000	0,6	4,5	1000	> 3000	> 10 ⁶	0 ± 50	---	---	0,39

SONDERAUSFÜHRUNGEN / SPECIAL CONFIGURATIONS

z.B. Trimmer unmagnetisch (Permeabilität < 1,001), andere Kapazitätsbereiche u.a. auf Anfrage
e.g. Trimmer non-magnetic (Permeability < 1,001), different capacitance ranges a.o. on inquiry