



TRONSER TRIMMER

for
professional
electronics

DATUM / DATE : 29.09.1988
ÄNDERUNG / REVISION : 10.04.2003

66-0301-00004-901

SAPHIRTRIMMER
SAPPHIRE TRIMMER

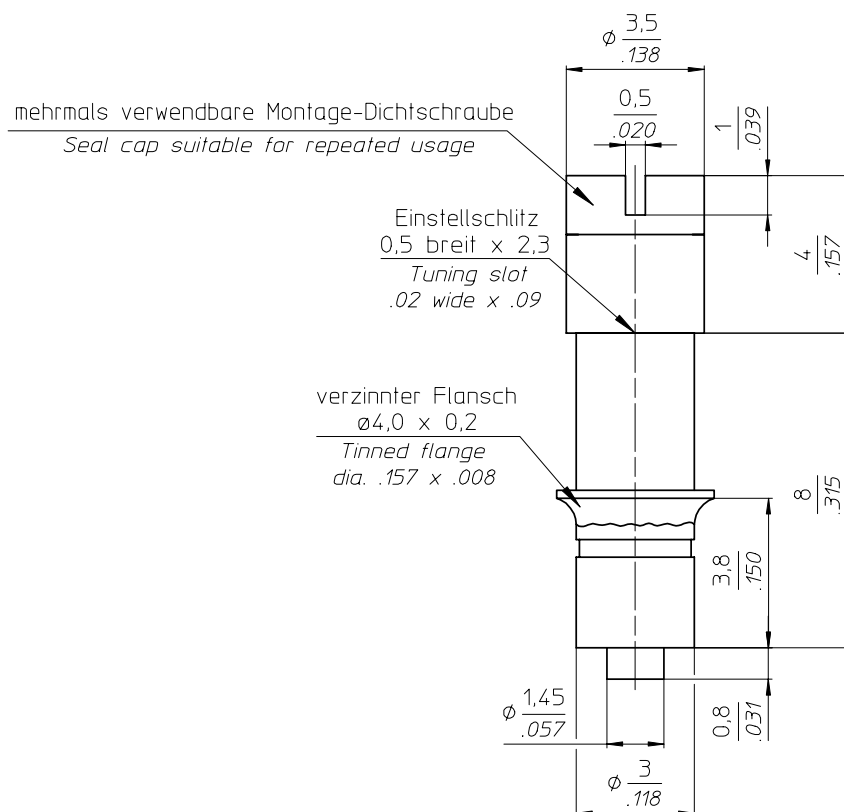

TECHNISCHE MERKMALE UND DATEN / TECHNICAL DATA

| | | | |
|---|---|--|---|
| EINSTELLDREHMOMENT <i>TUNING TORQUE</i> | 0,1 - 1,0 Ncm <i>0.14 - 1.4 in.oz.</i> | LEBENSDAUER <i>ROTATIONAL LIFE</i> | ≥ 75 Betätigungen, IEC 418 <i>≥ 75 cycles, IEC 418</i> |
| ANSCHLAGDREHMOMENT <i>STOP TORQUE</i> | max. 1,5 Ncm <i>max. 2.1 in.oz.</i> | VIBRATION <i>VIBRATION</i> | 60 g / 10 - 2000 Hz <i>60 g / 10 - 2000 Hz</i> |
| BEFESTIGUNGSDREHMOMENT <i>MOUNTING TORQUE</i> | --- | STOSSBEANSPRUCHUNG <i>SHOCK</i> | 1500 g / 0,5 ms <i>1500 g / 0.5 ms</i> |
| EINSTELLGENAUIGKEIT <i>ADJUSTMENT ACCURACY</i> | ≤ 1 x 10 ⁻³ vom Einstellwert <i>≤ 1 x 10⁻³ of adjusted value</i> | BETRIEBSTEMPERATUR <i>OPERATING TEMPERATURE</i> | -65°C ... +125°C <i>-65°C ... +125°C</i> |
| KONTAKTWIDERSTAND <i>CONTACT RESISTANCE</i> | < 0,001 Ω <i>< 0.001 Ω</i> | DIELEKTRIKUM <i>DIELECTRIC</i> | Saphir <i>Sapphire</i> |

| Teile - Nr. <i>Part - No.</i> | C _{min} [pF] | C _{max} [pF] | Prüfspannung <i>Test Voltage</i> [VDC] | Q-Faktor <i>Q-Factor</i> [@ 200MHz] | R _{isol.} <i>R_{insul.}</i> [MΩ] | TK _c [ppm / °C] | Maß A <i>Dim.A</i> [mm] | Maß B <i>Dim.B</i> [mm] | Gewicht <i>Weight</i> [ca. g] |
|----------------------------------|--------------------------|--------------------------|--|---|---|-------------------------------|-------------------------------|-------------------------------|-------------------------------------|
| 66-0301-00004-901 | 0,6 | 4,5 | 1000 | > 3000 | > 10 ⁶ | 0 ± 50 | --- | --- | 0,57 |

SONDERANFERTIGUNG / SPECIAL CONFIGURATION

Flansch verzinnt, Statoranschluß, Montage-Dichtschaube montiert
Tinned flange, stator connection, seal cap supplied mounted