



TRONSER TRIMMER

for
professional
electronics

DATUM / DATE : 27.09.2002
ÄNDERUNG / REVISION : 10.04.2003

66-02.4-00001-901

SAPHIRTRIMMER gegurtet
SAPPHIRE TRIMMER on tape & reel

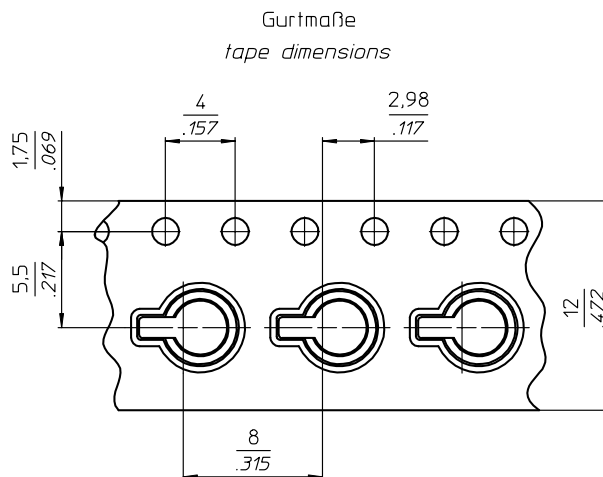
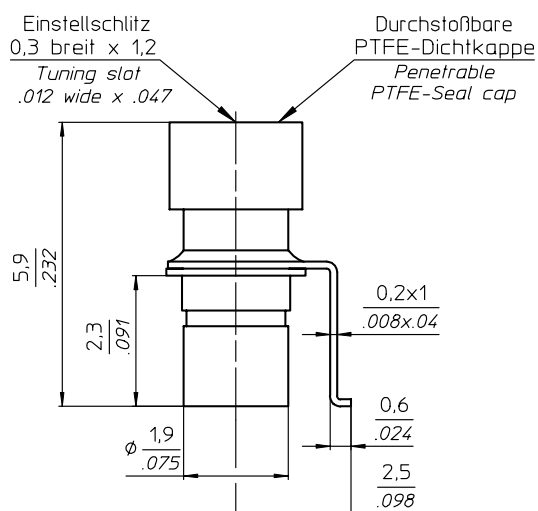

Rollendurchmesser: 330 mm, 900 Einheiten / Rolle
Reel diameter: 330 mm (13'), 900 units / reel

TECHNISCHE MERKMALE UND DATEN / TECHNICAL DATA

EINSTELLDREHMOMENT <i>TUNING TORQUE</i>	0,07 - 0,7 Ncm <i>0.1 - 1.0 in.oz.</i>	LEBENSDAUER <i>ROTATIONAL LIFE</i>	≥ 75 Betätigungen, IEC 418 <i>≥ 75 cycles, IEC 418</i>
ANSCHLAGDREHMOMENT <i>STOP TORQUE</i>	max. 0,8 Ncm <i>max. 1.1 in.oz.</i>	VIBRATION <i>VIBRATION</i>	60 g / 10 - 2000 Hz <i>60 g / 10 - 2000 Hz</i>
BEFESTIGUNGSDREHMOMENT <i>MOUNTING TORQUE</i>	--- ---	STOSSBEANSPRUCHUNG <i>SHOCK</i>	1500 g / 0,5 ms <i>1500 g / 0.5 ms</i>
EINSTELLGENAUIGKEIT <i>ADJUSTMENT ACCURACY</i>	≤ 1 x 10 ⁻³ vom Einstellwert <i>≤ 1 x 10⁻³ of adjusted value</i>	BETRIEBSTEMPERATUR <i>OPERATING TEMPERATURE</i>	-65°C ... +125°C <i>-65°C ... +125°C</i>
KONTAKTWIDERSTAND <i>CONTACT RESISTANCE</i>	< 0,001 Ω <i>< 0.001 Ω</i>	DIELEKTRIKUM <i>DIELECTRIC</i>	Saphir <i>Sapphire</i>

STANDARD - AUSFÜHRUNGEN / STANDARD CONFIGURATIONS

Teile - Nr. Part - No.	C _{min} [pF]	C _{max} [pF]	Prüfspannung Test Voltage [VDC]	Q-Faktor Q-Factor [@ 200MHz]	R _{isol.} R _{insul.} [MΩ]	TK _c [ppm / °C]	Maß A Dim.A [mm]	Maß B Dim.B [mm]	Gewicht Weight [ca. g]
66-0204-00001-901	0,3	1,2	1000	> 5000	> 10 ⁶	0 ± 50	---	---	0,15
66-0234-00001-901	0,3	1,2	1000	> 5000	> 10 ⁶	350 ± 75	---	---	0,15

SONDERAUSFÜHRUNGEN / SPECIAL CONFIGURATIONS

z.B. Trimmer unmagnetisch (Permeabilität < 1,001) u.a. auf Anfrage
e.g. Trimmer non-magnetic (Permeability < 1,001) a.o. on inquiry