



TRONSER TRIMMER

für die
professionelle
Elektronik

DATUM / *DATE* : 07.12.2004
ÄNDERUNG / *REVISION* : ---
KUNDE / *CUSTOMER* : Daniels Electronics

60-0730-15010-905

LUFTROHRTRIMMER
AIR TUBULAR TRIMMER

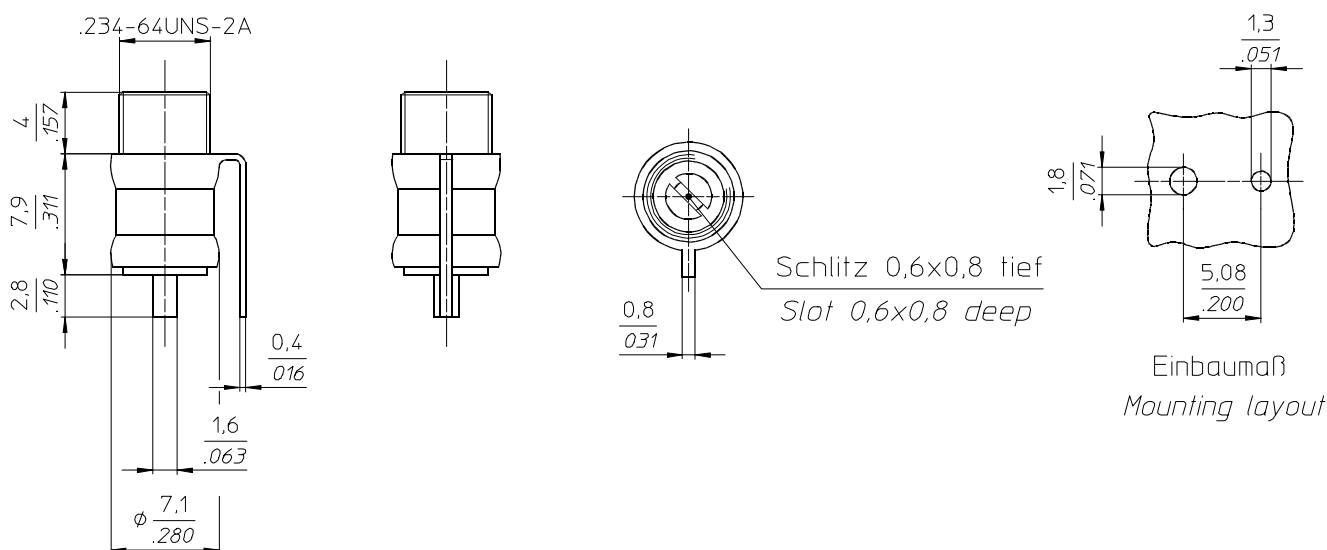

TECHNISCHE MERKMALE UND DATEN / *TECHNICAL DATA*

EINSTELLDREHMOMENT <i>TUNING TORQUE</i>	0,7 – 3,6 Ncm <i>1.0 – 5.0 in.oz.</i>	LEBENSDAUER <i>ROTATIONAL LIFE</i>	≥ 75 Betätigungen, IEC 418 <i>≥ 75 cycles, IEC 418</i>
ANSCHLAGDREHMOMENT <i>STOP TORQUE</i>	max. 8 Ncm <i>max. 11 in.oz.</i>	VIBRATION <i>VIBRATION</i>	60 g / 10 - 2000 Hz <i>60 g / 10 - 2000 Hz</i>
BEFESTIGUNGSDREHMOMENT <i>MOUNTING TORQUE</i>	---- Ncm <i>---- in.oz.</i>	STOSSBEANSPRUCHUNG <i>SHOCK</i>	1500 g / 0,5 ms <i>1500 g / 0.5 ms</i>
EINSTELLGENAUIGKEIT <i>ADJUSTMENT ACCURACY</i>	≤ 1 x10 ⁻³ vom Einstellwert <i>£ 1 x10⁻³ of adjusted value</i>	BETRIEBSTEMPERATUR <i>OPERATING TEMPERATURE</i>	-65°C ... +125°C <i>-65°C ... +125°C</i>
KONTAKTWIDERSTAND <i>CONTACT RESISTANCE</i>	< 0,001 Ω <i>< 0.001 W</i>	DIELEKTRIKUM <i>DIELECTRIC</i>	Luft (Luftspalt 0,15mm) <i>Air (Air gap 0,15mm)</i>

Teile - Nr. <i>Part - No.</i>	C _{min} [pF]	C _{max} [pF]	Prüfspannung <i>Test Voltage</i> [VDC]	Q-Faktor <i>Q-Factor</i> [@ 200MHz]	R _{isol.} R _{insul.} [MΩ]	TK _c [ppm / °C]	Maß A <i>Dim.A</i> [mm]	Maß B <i>Dim.B</i> [mm]	Gewicht <i>Weight</i> [ca. g]
60-0730-15010-905	0,8	10,0	500	> 5000	> 10 ⁶	0 ± 15	---	---	1,9

SONDERANFERTIGUNG / *SPECIAL CONFIGURATION*

Trimmer mit Hochtemperaturlot (Schmelzbereich 320 / 350°C) verlötet.
Trimmer soldered with high temperature solder (melting range 320 / 350°C).