



TRONSER TRIMMER

for
professional
electronics

DATUM / DATE : 15.01.1990
ÄNDERUNG / REVISION : 30.05.2006

60-0726-15...-901

LUFTROHRTRIMMER

AIRTUBULAR TRIMMER

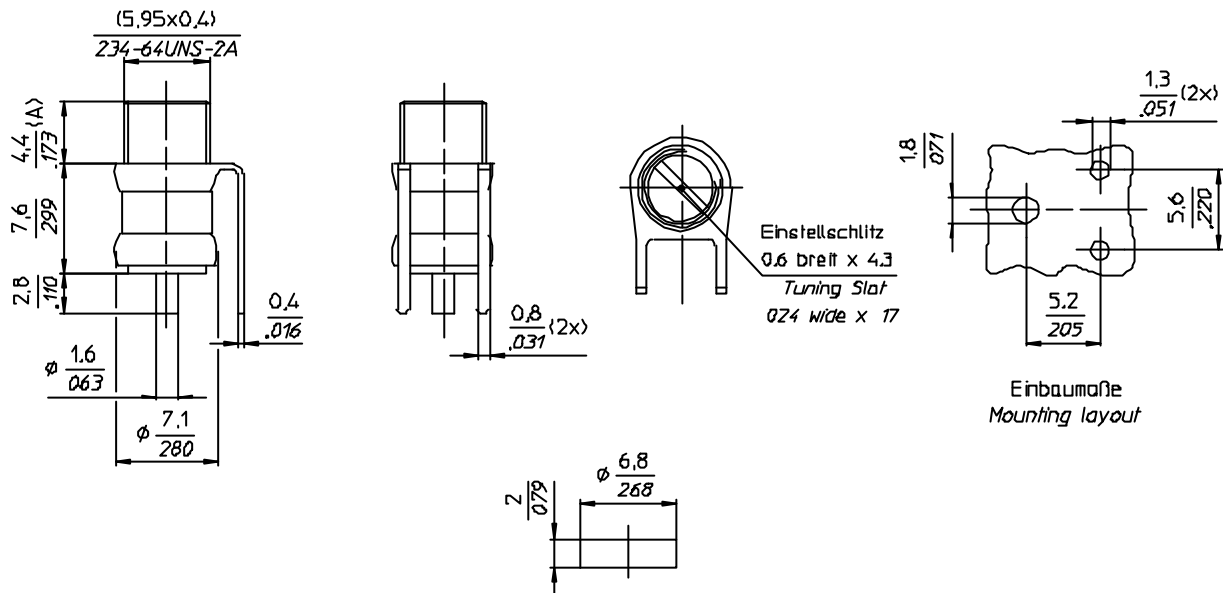

Dichtkappe lose Maß A +0.5
Sealcap unmounted Dim A +0.2

TECHNISCHE MERKMALE UND DATEN / TECHNICAL DATA

EINSTELLDREHMOMENT <i>TUNING TORQUE</i>	0,7 - 3,6 Ncm <i>0.9 - 5.0 in.oz.</i>	LEBENSDAUER <i>ROTATIONAL LIFE</i>	≥ 75 Betätigungen, IEC 418 <i>≥ 75 cycles, IEC 418</i>
ANSCHLAGDREHMOMENT <i>STOP TORQUE</i>	max. 8,0 Ncm <i>max. 11.1 in.oz.</i>	VIBRATION <i>VIBRATION</i>	60 g / 10 - 2000 Hz <i>60 g / 10 - 2000 Hz</i>
BEFESTIGUNGSDREHMOMENT <i>MOUNTING TORQUE</i>	max. --- Ncm <i>max. --- in.oz.</i>	STOSSBEANSPRUCHUNG <i>SHOCK</i>	1500 g / 0,5 ms <i>1500 g / 0.5 ms</i>
EINSTELLGENAUIGKEIT <i>ADJUSTMENT ACCURACY</i>	≤ 1 x 10 ⁻³ vom Einstellwert <i>≤ 1 x 10⁻³ of adjusted value</i>	BETRIEBSTEMPERATUR <i>OPERATING TEMPERATURE</i>	-65°C ... +125°C <i>-65°C ... +125°C</i>
KONTAKTWIDERSTAND <i>CONTACT RESISTANCE</i>	< 0,001 Ω <i>< 0.001 W</i>	DIELEKTRIKUM <i>DIELECTRIC</i>	Luft <i>Air</i>

Teile - Nr. Part - No.	C _{min} [pF]	C _{max} [pF]	Prüfspannung Test Voltage [VDC]	Q-Faktor Q-Factor [@ 200MHz]	R _{isol.} R _{insul.} [MΩ]	TK _c [ppm / °C]	Maß A Dim.A [mm]	Maß B Dim.B [mm]	Gewicht Weight [ca. g]
60-0726-15010-901	0,9	10,0	500	> 5000	> 10 ⁶	0 ± 15	---	---	1,9
60-0726-15014-901	1,1	14,0	300	> 5000	> 10 ⁶	0 ± 15	---	---	2,1

SONDERANFERTIGUNG / SPECIAL CONFIGURATION

englisches Gewinde, Dichtkappe lose
English thread, seal cap unmounted