



TRONSER TRIMMER

for
professional
electronics

DATUM / *DATE* : 09.01.2001
ÄNDERUNG / *REVISION* : 17.07.2006

60-0614...-600 LUFTROHRTRIMMER unmagnetisch *AIRTUBULAR TRIMMER non-magnetic*

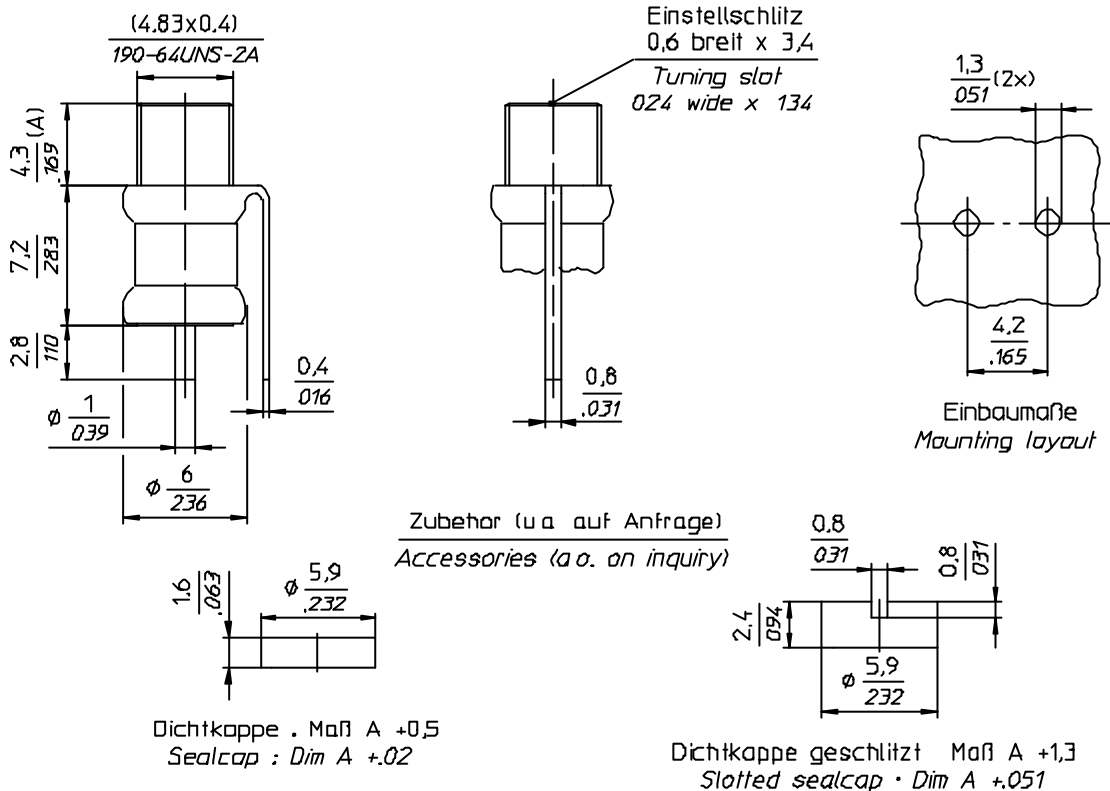

TECHNISCHE MERKMALE UND DATEN / *TECHNICAL DATA*

EINSTELLDREHMOMENT <i>TUNING TORQUE</i>	0,3 - 3,0 Ncm <i>0.4 - 4.2 in.oz.</i>	LEBENSDAUER <i>ROTATIONAL LIFE</i>	≥ 75 Betätigungen, IEC 418 <i>≥ 75 cycles, IEC 418</i>
ANSCHLAGDREHMOMENT <i>STOP TORQUE</i>	max. 6,0 Ncm <i>max. 8.3 in.oz.</i>	VIBRATION <i>VIBRATION</i>	60 g / 10 - 2000 Hz <i>60 g / 10 - 2000 Hz</i>
BEFESTIGUNGSDREHMOMENT <i>MOUNTING TORQUE</i>	max. --- Ncm <i>max. --- in.oz.</i>	STOSSBEANSPRUCHUNG <i>SHOCK</i>	1500 g / 0,5 ms <i>1500 g / 0.5 ms</i>
EINSTELLGENAUIGKEIT <i>ADJUSTMENT ACCURACY</i>	≤ 1 x 10 ⁻³ vom Einstellwert <i>≤ 1 x 10⁻³ of adjusted value</i>	BETRIEBSTEMPERATUR <i>OPERATING TEMPERATURE</i>	-65°C ... +125°C <i>-65°C ... +125°C</i>
KONTAKTWIDERSTAND <i>CONTACT RESISTANCE</i>	< 0,001 Ω <i>< 0.001 W</i>	DIELEKTRIKUM <i>DIELECTRIC</i>	Luft <i>Air</i>

STANDARD - AUSFÜHRUNGEN / *STANDARD CONFIGURATIONS*

Teile - Nr. <i>Part - No.</i>	C _{min} [pF]	C _{max} [pF]	Prüfspannung <i>Test Voltage</i> [VDC]	Q-Faktor <i>Q-Factor</i> [@ 200MHz]	R _{isol.} <i>R_{isol.}</i> [MΩ]	TK _c [ppm / °C]	Maß A <i>Dim.A</i> [mm]	Maß B <i>Dim.B</i> [mm]	Gewicht <i>Weight</i> [ca. g]
60-0614-10007-600	0,7	7,0	250	> 5000	> 10 ⁶	50 ± 50	4,3	---	1,4

Permeabilität < 1,001 / *Permeability < 1,001*

SONDERAUSFÜHRUNGEN (auf Anfrage) / *SPECIAL CONFIGURATIONS (on inquiry)*

z.B. verlängerte Welle, Hochtemperatur-Lot u.a.
e.g. extended shaft, high temperature solder a.o.