



TRONSER TRIMMER

for
professional
electronics

DATUM / DATE : 09.01.2007
ÄNDERUNG / REVISION : ---

60-0603-10007-600

LUFTROHRTRIMMER

AIRTUBULAR TRIMMER

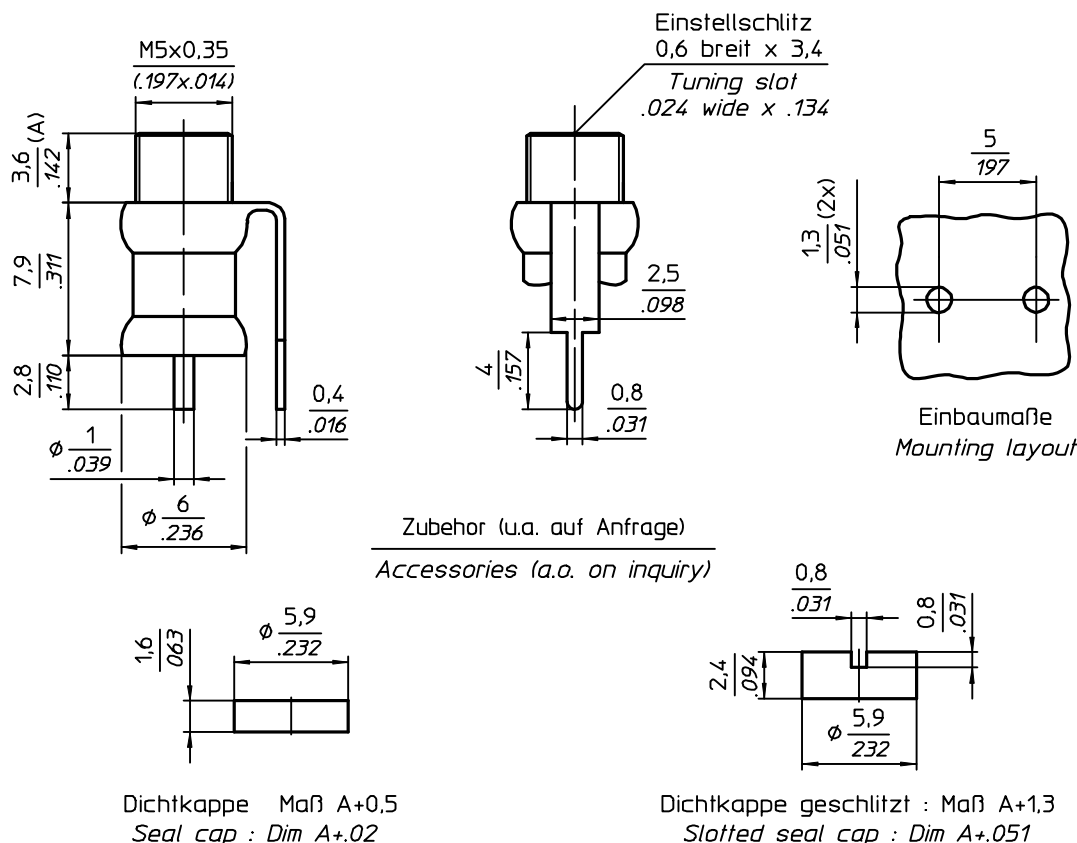

TECHNISCHE MERKMALE UND DATEN / TECHNICAL DATA

EINSTELLDREHMOMENT <i>TUNING TORQUE</i>	0,3 - 3,0 Ncm <i>0.4 - 4.2 in.oz.</i>	LEBENSDAUER <i>ROTATIONAL LIFE</i>	? 75 Betätigungen, IEC 418 <i>? 75 cycles, IEC 418</i>
ANSCHLAGDREHMOMENT <i>STOP TORQUE</i>	max. 6,0 Ncm <i>max. 8.3 in.oz.</i>	VIBRATION <i>VIBRATION</i>	60 g / 10 - 2000 Hz <i>60 g / 10 - 2000 Hz</i>
BEFESTIGUNGSDREHMOMENT <i>MOUNTING TORQUE</i>	max. --- Ncm <i>max. --- in.oz.</i>	STOSSBEANSPRUCHUNG <i>SHOCK</i>	1500 g / 0,5 ms <i>1500 g / 0.5 ms</i>
EINSTELLGENAUIGKEIT <i>ADJUSTMENT ACCURACY</i>	? 1×10^{-3} vom Einstellwert <i>? 1×10^{-3} of adjusted value</i>	BETRIEBSTEMPERATUR <i>OPERATING TEMPERATURE</i>	-65°C ... +125°C <i>-65°C ... +125°C</i>
KONTAKTWIDERSTAND <i>CONTACT RESISTANCE</i>	< 0,001 ? <i>< 0.001 ?</i>	DIELEKTRIKUM <i>DIELECTRIC</i>	Luft <i>Air</i>

STANDARD - AUSFÜHRUNGEN / STANDARD CONFIGURATIONS

Teile - Nr. Part - No.	C _{min} [pF]	C _{max} [pF]	Prüfspannung Test Voltage [VDC]	Q-Faktor Q-Factor [@ 200MHz]	R _{isol.} R _{insul.} [M?]	TK _c [ppm / °C]	Maß A Dim.A [mm]	Maß B Dim.B [mm]	Gewicht Weight [ca. g]
60-0603-10007-600	0,8	7,0	250	> 5000	> 10 ⁶	60 ? 30	3,6	---	1,4

SONDERAUSFÜHRUNGEN / SPECIAL CONFIGURATIONS

Trimmer unmagnetisch
Trimmer non-magnetic