



DATUM / DATE : 17.12.1992
 ÄNDERUNG / REVISION : 21.03.2005

TRONSER TRIMMER

for
professional
electronics

60-0421... LUFTRÖHRTRIMMER AIRTUBULAR TRIMMER

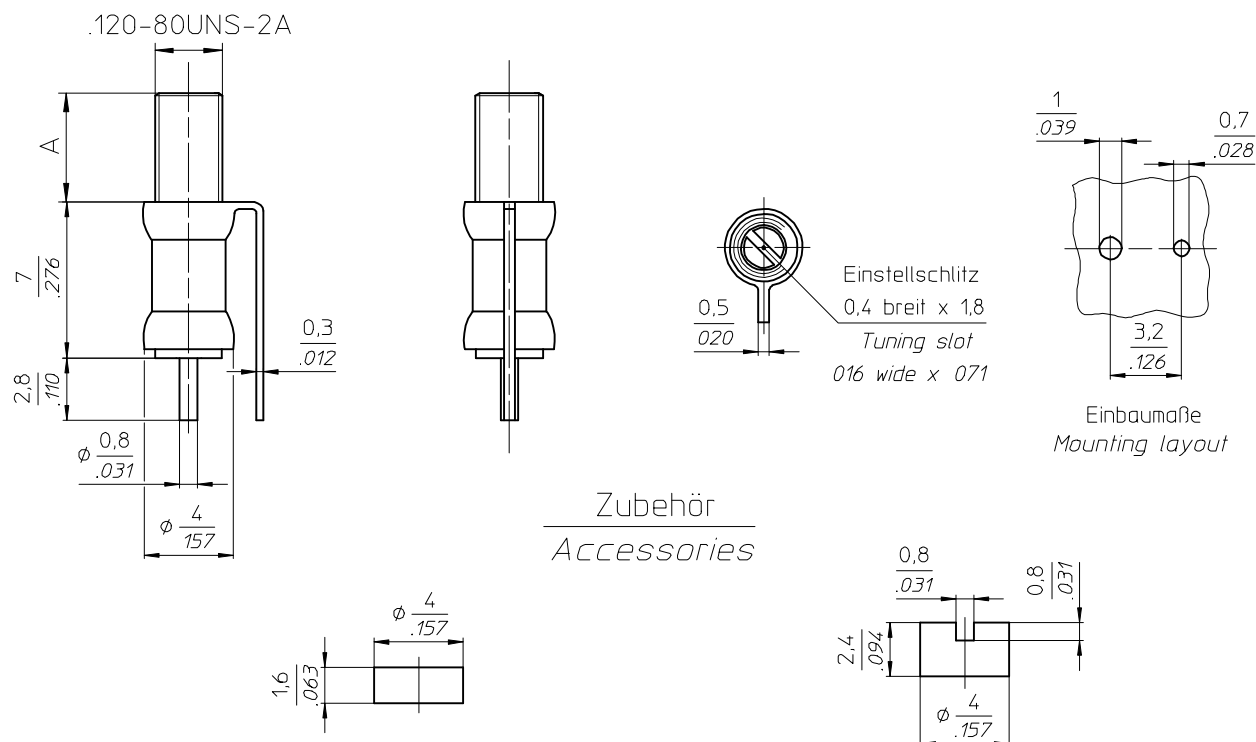

-030 Dichtkappe lose : Maß A +0,5
 -030 Sealcap unmounted : Dim A +.02

-019 Dichtkappe geschlitzt lose : Maß A +1,3
 -019 Slotted sealcap unmounted : Dim A +.051

TECHNISCHE MERKMALE UND DATEN / TECHNICAL DATA

EINSTELLDDREHMOMENT <i>TUNING TORQUE</i>	0,2 – 2,0 Ncm <i>0.3 - 2.8 in.oz.</i>	LEBENSDAUER <i>ROTATIONAL LIFE</i>	≥ 75 Betätigungen, IEC 418 <i>≥ 75 cycles, IEC 418</i>
ANSCHLAGDREHMOMENT <i>STOP TORQUE</i>	max. 2,5 Ncm <i>max. 3.4 in.oz.</i>	VIBRATION <i>VIBRATION</i>	60 g / 10 - 2000 Hz <i>60 g / 10 - 2000 Hz</i>
BEFESTIGUNGSDREHMOMENT <i>MOUNTING TORQUE</i>	max. --- Ncm <i>max. --- in.oz.</i>	STOSSBEANSPRUCHUNG <i>SHOCK</i>	1500 g / 0,5 ms <i>1500 g / 0.5 ms</i>
EINSTELLGENAUIGKEIT <i>ADJUSTMENT ACCURACY</i>	≤ 1 x 10 ⁻³ vom Einstellwert <i>≤ 1 x 10⁻³ of adjusted value</i>	BETRIEBSTEMPERATUR <i>OPERATING TEMPERATURE</i>	-65°C ... +125°C <i>-65°C ... +125°C</i>
KONTAKTWIDERSTAND <i>CONTACT RESISTANCE</i>	< 0,001 Ω <i>< 0.001 W</i>	DIELEKTRIKUM <i>DIELECTRIC</i>	Luft (Luftspalt 0,10 mm) <i>Air (Air gap 0,10 mm)</i>

Teile - Nr. Part - No.	C _{min} [pF]	C _{max} [pF]	Prüfspannung Test Voltage [VDC]	Q-Faktor Q-Factor [@ 200MHz]	R _{isol.} R _{insul.} [MΩ]	TK _c [ppm / °C]	Maß A Dim.A [mm]	Maß B Dim.B [mm]	Gewicht Weight [ca. g]
60-0421-10003-000	0,4	3,5	250	> 5000	> 10 ⁶	0 ± 50	4,9	---	1,0
60-0421-10005-000	0,6	5,0	250	> 5000	> 10 ⁶	0 ± 50	5,8	---	1,0

SONDERAUSFÜHRUNGEN / SPECIAL CONFIGURATIONS

z.B. Trimmer unmagnetisch, verlängerte Welle, Hochtemperatur-Lot u.a. auf Anfrage
 e.g. *Trimmer non-magnetic, extended shaft, high temperature solder a.o. on inquiry*