



TRONSER TRIMMER

for
professional
electronics

DATUM / DATE : 31.08.2004
ÄNDERUNG / REVISION : 13.12.2005

10-1606-82...-904 LUFTPLATTENTRIMMER AIRPLATE TRIMMER

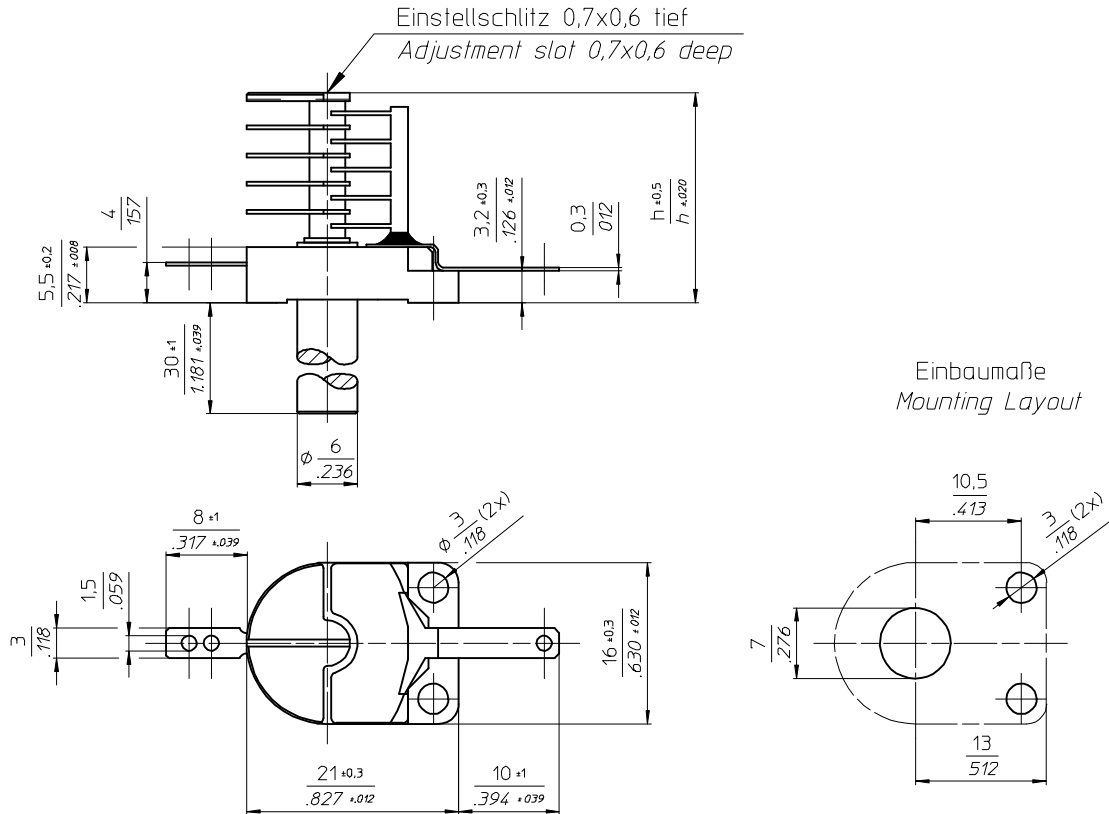

TECHNISCHE MERKMALE UND DATEN / TECHNICAL DATA

EINSTELLDREHMOMENT <i>TUNING TORQUE</i>	2,5 - 5,0 Ncm 3.5 - 7.0 in.oz.	KERAMIK <i>CERAMIC</i>	DIN 40685 / 221 , silikonisiert <i>DIN 40685 / 221 , siliconized</i>
Q-FAKTOR <i>Q-FACTOR</i>	> 5000 bei 1 MHz > 5000 @ 1 MHz	DIELEKTRIKUM <i>DIELECTRIC</i>	Luft <i>Air</i>
BETRIEBSTEMPERATUR <i>OPERATING TEMPERATURE</i>	-65°C ... +125°C -65°C ... +125°C		

Teile - Nr. Part - No.	C _{min} [pF]	C _{max} [pF]	Plattenzahl No. Of Plates Stator / Rotor	Luftspalt Air Gap [mm]	Prüfspannung Test Voltage [~V _{eff}]	R _{isol.} R _{insul.} [MΩ]	TK _c [ppm / °C]	Höhe h Height h [mm]	Gewicht Weight [ca. g]
10-1606-82006-904	1,5	6,0	3 / 3	1,00	1800	> 10 ³	45 ± 20	15,1	16,0
10-1606-82010-904	2,8	9,0	5 / 5	1,00	1800	> 10 ³	45 ± 20	20,9	17,2
10-1606-82012-904	3,5	12,0	7 / 7	1,00	1800	> 10 ³	45 ± 20	26,3	18,9

SONDERANFERTIGUNG / SPECIAL CONFIGURATION

Trimmer mit verlängerter Rotorwelle
Trimmer with extended rotor shaft