



TRONSER TRIMMER

for
professional
electronics

DATUM / DATE : 05.02.2001
ÄNDERUNG / REVISION : 10.04.2003

66-0337-0000.-600 SAPHIRTRIMMER unmagnetisch SAPPHIRE TRIMMER non-magnetic

Zubehör/ Accessories

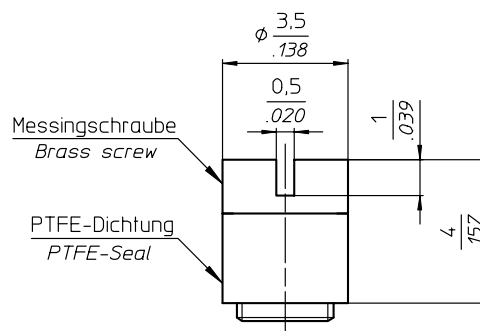
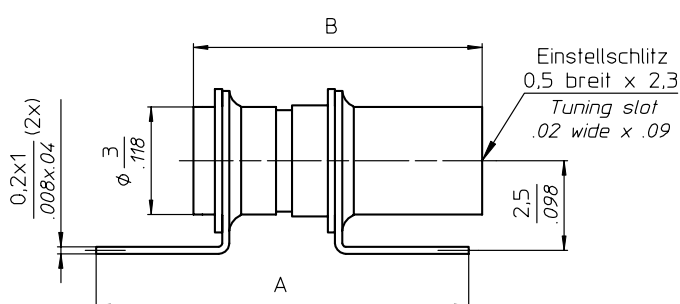

mehrmals verwendbare Montage-Dichtschraube
Seal cap suitable for repeated usage

TECHNISCHE MERKMALE UND DATEN / TECHNICAL DATA

| | | | |
|---|---|--|--|
| EINSTELLDREHMOMENT <i>TUNING TORQUE</i> | 0,1 - 1,0 Ncm <i>0.14 - 1.4 in.oz.</i> | LEBENSDAUER <i>ROTATIONAL LIFE</i> | ≥ 75 Betätigungen, IEC 418 ≥ 75 cycles, IEC 418 |
| ANSCHLAGDREHMOMENT <i>STOP TORQUE</i> | max. 1,5 Ncm <i>max. 2.1 in.oz.</i> | VIBRATION <i>VIBRATION</i> | 60 g / 10 - 2000 Hz <i>60 g / 10 - 2000 Hz</i> |
| BEFESTIGUNGSDREHMOMENT <i>MOUNTING TORQUE</i> | --- | STOSSBEANSPRUCHUNG <i>SHOCK</i> | 1500 g / 0,5 ms <i>1500 g / 0.5 ms</i> |
| EINSTELLGENAUIGKEIT <i>ADJUSTMENT ACCURACY</i> | ≤ 1 x 10 ⁻³ vom Einstellwert ≤ 1 x 10 ⁻³ of adjusted value | BETRIEBSTEMPERATUR <i>OPERATING TEMPERATURE</i> | -65°C ... +125°C -65°C ... +125°C |
| KONTAKTWIDERSTAND <i>CONTACT RESISTANCE</i> | < 0,001 Ω < 0.001 Ω | DIELEKTRIKUM <i>DIELECTRIC</i> | Saphir <i>Sapphire</i> |

STANDARD - AUSFÜHRUNGEN / STANDARD CONFIGURATIONS

| Teile - Nr. Part - No. | C _{min} [pF] | C _{max} [pF] | Prüfspannung Test Voltage [VDC] | Q-Faktor Q-Factor [@ 200MHz] | R _{isol.} R _{insul.} [MΩ] | TK _c [ppm/°C] | Maß A Dim.A [mm] | Maß B Dim.B [mm] | Gewicht Weight [ca. g] |
|---------------------------|--------------------------|--------------------------|---------------------------------------|------------------------------------|---|-----------------------------|------------------------|------------------------|------------------------------|
| 66-0337-00002-600 | 0,4 | 2,5 | 1000 | > 4000 | > 10 ⁶ | 350 ± 75 | 9,2 | 5,8 | 0,31 |
| 66-0337-00004-600 | 0,6 | 4,5 | 1000 | > 3000 | > 10 ⁶ | 350 ± 75 | 10,4 | 8,0 | 0,39 |
| 66-0337-00008-600 | 0,8 | 8,0 | 1000 | > 2000 | > 10 ⁶ | 350 ± 75 | 13,8 | 12,3 | 0,53 |

Trimmer unmagnetisch (Permeabilität < 1,001)
Trimmer non-magnetic (Permeability < 1,001)