



# TRONSER TRIMMER

for  
professional  
electronics

DATUM / DATE : 17.06.1994  
ÄNDERUNG / REVISION : 10.04.2003

## 66-0303-00004-902

SAPHIRTRIMMER  
SAPPHIRE TRIMMER

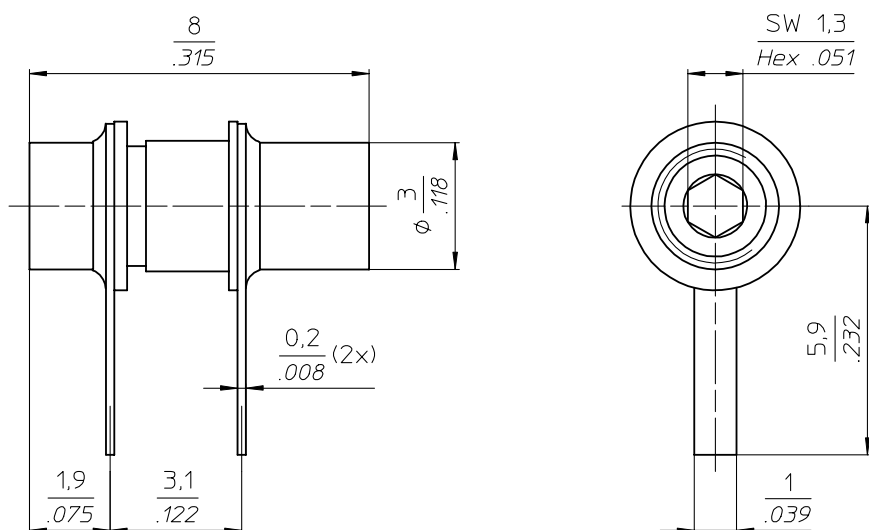

### TECHNISCHE MERKMALE UND DATEN / TECHNICAL DATA

EINSTELLDREHMOMENT <i>TUNING TORQUE</i>	0,1 - 1,0 Ncm <i>0.14 - 1.4 in.oz.</i>	LEBENSDAUER <i>ROTATIONAL LIFE</i>	≥ 75 Betätigungen, IEC 418 <i>≥ 75 cycles, IEC 418</i>
ANSCHLAGDREHMOMENT <i>STOP TORQUE</i>	max. 1,5 Ncm <i>max. 2.1 in.oz.</i>	VIBRATION <i>VIBRATION</i>	60 g / 10 - 2000 Hz <i>60 g / 10 - 2000 Hz</i>
BEFESTIGUNGSDREHMOMENT <i>MOUNTING TORQUE</i>	---	STOSSBEANSPRUCHUNG <i>SHOCK</i>	1500 g / 0,5 ms <i>1500 g / 0.5 ms</i>
EINSTELLGENAUIGKEIT <i>ADJUSTMENT ACCURACY</i>	≤ 1 x10 <sup>-3</sup> vom Einstellwert <i>≤ 1 x10<sup>-3</sup> of adjusted value</i>	BETRIEBSTEMPERATUR <i>OPERATING TEMPERATURE</i>	-65°C ... +125°C <i>-65°C ... +125°C</i>
KONTAKTWIDERSTAND <i>CONTACT RESISTANCE</i>	< 0,001 Ω <i>&lt; 0.001 Ω</i>	DIELEKTRIKUM <i>DIELECTRIC</i>	Saphir <i>Sapphire</i>

Teile - Nr. Part - No.	C <sub>min</sub> [pF]	C <sub>max</sub> [pF]	Prüfspannung Test Voltage [VDC]	Q-Faktor Q-Factor [@ 200MHz]	R <sub>isol.</sub> R <sub>insul.</sub> [MΩ]	TK <sub>c</sub> [ppm/°C]	Maß A Dim.A [mm]	Maß B Dim.B [mm]	Gewicht Weight [ca. g]
66-0303-00004-902	0,6	4,5	1000	> 3000	> 10 <sup>6</sup>	0 ± 50	---	---	0,40

### SONDERANFERTIGUNG / SPECIAL CONFIGURATION

Einbaumaße, Lötflächen-Oberfläche, Rotor mit Innensechskant  
*Mounting layout, solder tag finish, rotor with hex socket head*