



TRONSER TRIMMER

for
professional
electronics

DATUM / DATE : 16.09.1992
ÄNDERUNG / REVISION : 20.08.2008

60-1201-86009-000

LUFTRÖHRTRIMMER
AIR TUBULAR TRIMMER

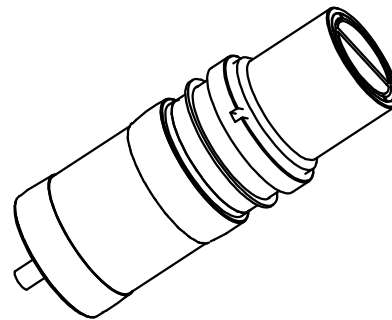
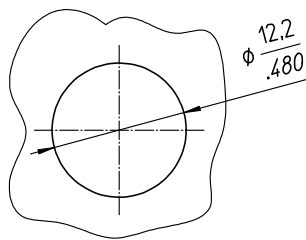
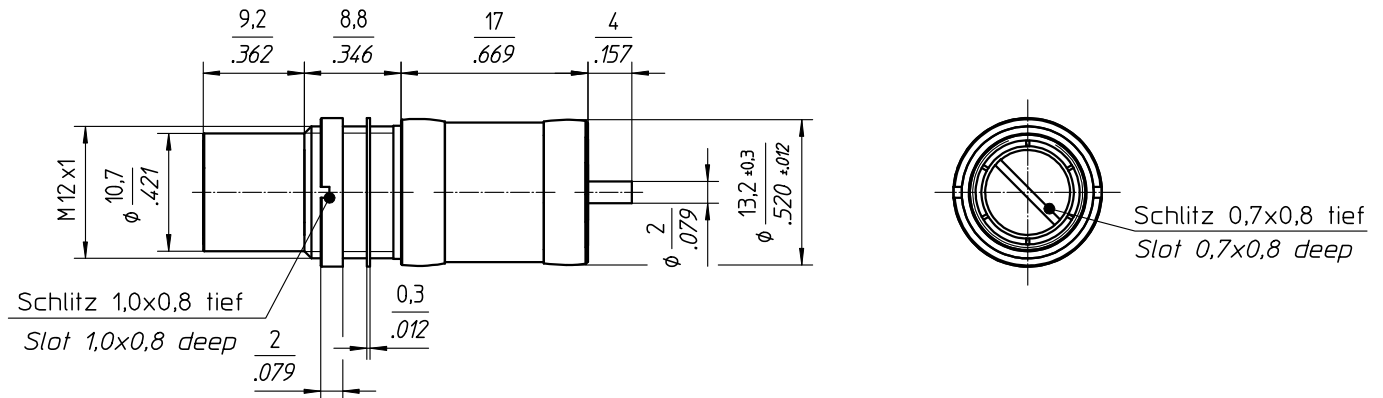

TECHNISCHE MERKMALE UND DATEN / TECHNICAL DATA

EINSTELLDREHMOMENT <i>TUNING TORQUE</i>	0,7 - 4,2 Ncm <i>0.9 - 5.8 in.oz.</i>	LEBENSDAUER <i>ROTATIONAL LIFE</i>	≥ 75 Betätigungen, IEC 418 ≥ 75 cycles, IEC 418
ANSCHLAGDREHMOMENT <i>STOP TORQUE</i>	max. 8,0 Ncm <i>max. 11.1 in.oz.</i>	VIBRATION <i>VIBRATION</i>	60 g / 10 - 2000 Hz 60 g / 10 - 2000 Hz
BEFESTIGUNGSDREHMOMENT <i>MOUNTING TORQUE</i>	max. 100 Ncm <i>max. 139 in.oz.</i>	STOSSBEANSPRUCHUNG <i>SHOCK</i>	1500 g / 0,5 ms 1500 g / 0.5 ms
EINSTELLENAUIGKEIT <i>ADJUSTMENT ACCURACY</i>	≤ 1 × 10 ⁻³ vom Einstellwert ≤ 1 × 10 ⁻³ of adjusted value	BETRIEBSTEMPERATUR <i>OPERATING TEMPERATURE</i>	-65°C ... +125°C -65°C ... +125°C
KONTAKTWIDERSTAND <i>CONTACT RESISTANCE</i>	< 0,001 Ω < 0.001 Ω	DIELEKTRIKUM <i>DIELECTRIC</i>	Luft Air

STANDARD - AUSFÜHRUNGEN / STANDARD CONFIGURATIONS

Teile - Nr. Part - No.	C _{min} [pF]	C _{max} [pF]	Prüfspannung Test Voltage [VDC]	Q-Faktor Q-Factor [@ 200MHz]	R _{isol.} R _{insul.} [MΩ]	TK _c [ppm/°C]	Maß A Dim.A [mm]	Maß B Dim.B [mm]	Gewicht Weight [ca. g]
60-1201-86009-000	2,5	9,0	2000	> 2000	> 10 ⁶	---	---	---	17,0

SONDERAUSFÜHRUNGEN (auf Anfrage) / SPECIAL CONFIGURATIONS (on inquiry)

z.B. Trimmer unmagnetisch, verlängerte Welle, Hochtemperatur-Lot u.a.
e.g. Trimmer non-magnetic, extended shaft, high temperature solder a.o.