



TRONSER TRIMMER

for
professional
electronics

DATUM / *DATE* : 15.10.1987
ÄNDERUNG / *REVISION* : 30.05.2006

60-0741... LUFTRÖHRTRIMMER *AIRTUBULAR TRIMMER*

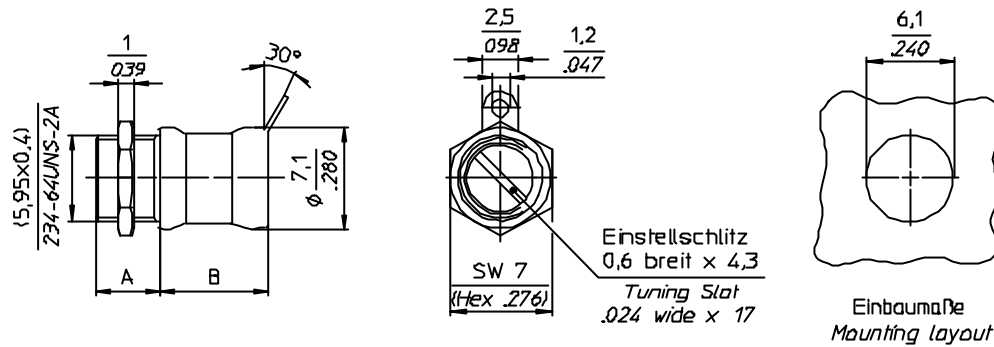

Zubehör (u.a. auf Anfrage)
Accessories (a.o. on inquiry)

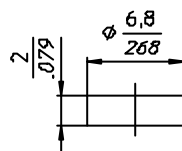

Dichtkappe lose · Maß A +0,5
Sealcap unmounted Dim A +.02

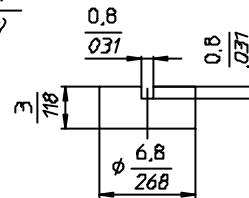

Dichtkappe geschlitzt lose Maß A +1,4
Slotted sealcap unmounted Dim A +.055

TECHNISCHE MERKMALE UND DATEN / [TECHNICAL DATA](#)

EINSTELLDREHMOMENT <i>TUNING TORQUE</i>	0,7 - 3,6 Ncm <i>0.9 - 5.0 in.oz.</i>	LEBENSDAUER <i>ROTATIONAL LIFE</i>	≥ 75 Betätigungen, IEC 418 <i>≥ 75 cycles, IEC 418</i>
ANSCHLAGDREHMOMENT <i>STOP TORQUE</i>	max. 8,0 Ncm <i>max. 11.1 in.oz.</i>	VIBRATION <i>VIBRATION</i>	60 g / 10 - 2000 Hz <i>60 g / 10 - 2000 Hz</i>
BEFESTIGUNGSDREHMOMENT <i>MOUNTING TORQUE</i>	max. 50 Ncm <i>max. 70 in.oz.</i>	STOSSBEANSPRUCHUNG <i>SHOCK</i>	1500 g / 0,5 ms <i>1500 g / 0.5 ms</i>
EINSTELLGENAUIGKEIT <i>ADJUSTMENT ACCURACY</i>	≤ 1 x 10 ⁻³ vom Einstellwert <i>£ 1 x 10⁻³ of adjusted value</i>	BETRIEBSTEMPERATUR <i>OPERATING TEMPERATURE</i>	-65°C ... +125°C <i>-65°C ... +125°C</i>
KONTAKTWIDERSTAND <i>CONTACT RESISTANCE</i>	< 0,001 Ω <i>< 0.001 W</i>	DIELEKTRIKUM <i>DIELECTRIC</i>	Luft <i>Air</i>

STANDARD - AUSFÜHRUNGEN / [STANDARD CONFIGURATIONS](#)

Teile - Nr. <i>Part - No.</i>	C _{min} [pF]	C _{max} [pF]	Prüfspannung <i>Test Voltage</i> [VDC]	Q-Faktor <i>Q-Factor</i> [@ 200MHz]	R _{isol.} <i>R_{isol.}</i> [MΩ]	TK _c [ppm/°C]	Maß A <i>Dim.A</i> [mm]	Maß B <i>Dim.B</i> [mm]	Gewicht <i>Weight</i> [ca. g]
60-0741-15010-000	0,8	10,0	500	> 5000	> 10 ⁶	0 ± 15	4,4	7,5	1,9
60-0741-15014-000	1,0	14,0	300	> 5000	> 10 ⁶	0 ± 15	4,4	7,5	2,1
60-0741-15020-000	1,0	20,0	300	> 1000	> 10 ⁶	30 ± 20	5,9	12,5	2,9
60-0741-15025-000	1,0	25,0	300	> 1000	> 10 ⁶	50 ± 50	5,9	12,5	3,1
60-0741-15030-000	1,0	30,0	300	> 500	> 10 ⁶	30 ± 20	6,8	16,7	3,6

SONDERAUSFÜHRUNGEN (auf Anfrage) / [SPECIAL CONFIGURATIONS \(on inquiry\)](#)

z.B. Trimmer unmagnetisch, verlängerte Welle, Hochtemperatur-Lot u.a.
e.g. Trimmer non-magnetic, extended shaft, high temperature solder a.o.