



TRONSER TRIMMER

for
professional
electronics

DATUM / *DATE* : 28.09.2004
ÄNDERUNG / *REVISION* : ----
KUNDE / *CUSTOMER* : ----

60-0720-15...-000 LUFTRÖHRTRIMMER *AIRTUBULAR TRIMMER*

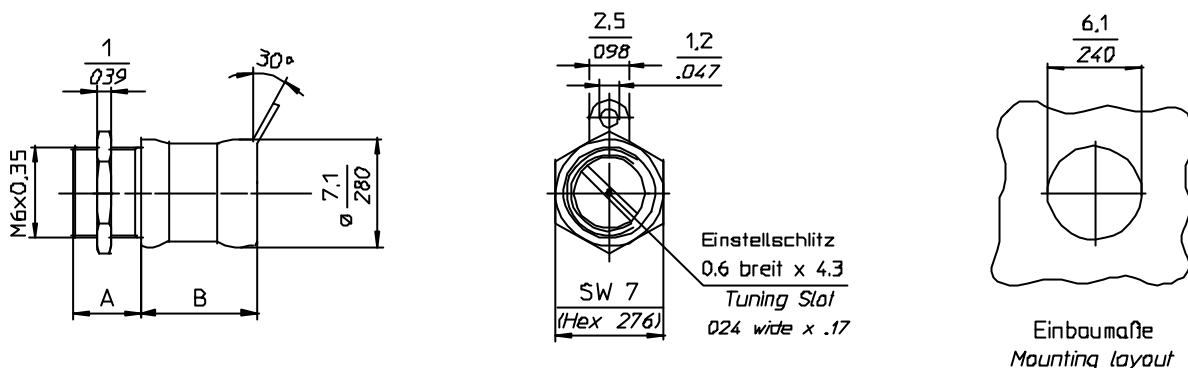

Zubehör *Accessories*

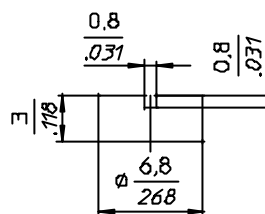
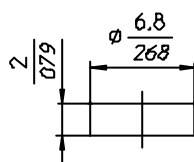

-030 Dichtkappe lose Maß A +0,5
-030 Sealcap unmounted · Dim A + 02

-019 Dichtkappe geschlitzt lose · Maß A +1.4
-019 Slotted sealcap unmounted · Dim A + 055

Bestell-Beispiel Trimmer 1,0-14,0 pF mit loser Dichtkappe = Bestell-Nr 60-0720-15014-030
How to order : Trimmer 1.0-14.0 pF with unmounted sealcap = Order-No. 60-0720-15014-030

TECHNISCHE MERKMALE UND DATEN / *TECHNICAL DATA*

EINSTELLDREHMOMENT <i>TUNING TORQUE</i>	0,7 - 3,6 Ncm <i>0.9 - 5.0 in.oz.</i>	LEBENSDAUER <i>ROTATIONAL LIFE</i>	≥ 75 Betätigungen, IEC 418 <i>≥ 75 cycles, IEC 418</i>
ANSCHLAGDREHMOMENT <i>STOP TORQUE</i>	max. 8,0 Ncm <i>max. 11.1 in.oz.</i>	VIBRATION <i>VIBRATION</i>	60 g / 10 - 2000 Hz <i>60 g / 10 - 2000 Hz</i>
BEFESTIGUNGSDREHMOMENT <i>MOUNTING TORQUE</i>	max. 50 Ncm <i>max. 70 in.oz.</i>	STOSSBEANSPRUCHUNG <i>SHOCK</i>	1500 g / 0,5 ms <i>1500 g / 0.5 ms</i>
EINSTELLGENAUIGKEIT <i>ADJUSTMENT ACCURACY</i>	≤ 1 x 10 ⁻³ vom Einstellwert <i>£ 1 x 10⁻³ of adjusted value</i>	BETRIEBSTEMPERATUR <i>OPERATING TEMPERATURE</i>	-65°C ... +125°C <i>-65°C ... +125°C</i>
KONTAKTWIDERSTAND <i>CONTACT RESISTANCE</i>	< 0,001 Ω <i>< 0.001 W</i>	DIELEKTRIKUM <i>DIELECTRIC</i>	Luft (Luftspalt 0,15 mm) <i>Air (Air gap 0,15 mm)</i>

Teile - Nr. <i>Part - No.</i>	C _{min} [pF]	C _{max} [pF]	Prüfspannung <i>Test Voltage</i> [VDC]	Q-Faktor <i>Q-Factor</i> [@ 200MHz]	R _{isol.} R _{insul.} [MΩ]	TK _c [ppm/°C]	Maß A <i>Dim.A</i> [mm]	Maß B <i>Dim.B</i> [mm]	Gewicht <i>Weight</i> [ca. g]
60-0720-15010-000	0,8	10,0	500	> 5000	> 10 ⁶	0 ± 15	4,4	7,5	1,9
60-0720-15014-000	1,0	14,0	300	> 5000	> 10 ⁶	0 ± 15	4,4	7,5	2,1

SONDERAUSFÜHRUNGEN / *SPECIAL CONFIGURATIONS*

z.B. Trimmer unmagnetisch, verlängerte Welle, Hochtemperatur-Lot u.a. auf Anfrage
e.g. Trimmer non-magnetic, extended shaft, high temperature solder a.o. on inquiry