



# TRONSER TRIMMER

für die  
professionelle  
Elektronik

DATUM / *DATE* : 06.12.2004  
ÄNDERUNG / *REVISION* : ---  
KUNDE / *CUSTOMER* : Daniels Electronics

## 60-0422-10005-903

LUFTROHRTRIMMER  
*AIR TUBULAR TRIMMER*

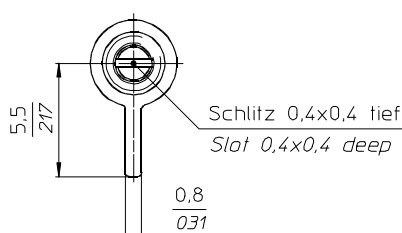
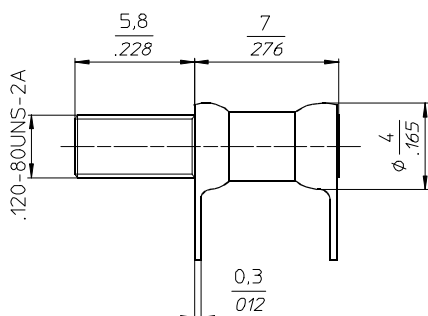

Einbaumaße  
*Mounting layout*

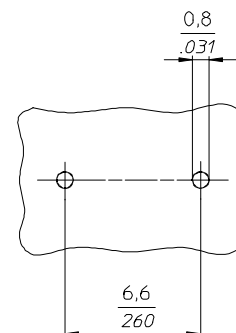

### TECHNISCHE MERKMALE UND DATEN / *TECHNICAL DATA*

EINSTELLDREHMOMENT <i>TUNING TORQUE</i>	0,2 – 2,0 Ncm <i>0.3 – 2.8 in.oz.</i>	LEBENSDAUER <i>ROTATIONAL LIFE</i>	≥ 75 Betätigungen, IEC 418 <i>≥ 75 cycles, IEC 418</i>
ANSCHLAGDREHMOMENT <i>STOP TORQUE</i>	max. 2,5 Ncm <i>max. 3.5 in.oz.</i>	VIBRATION <i>VIBRATION</i>	60 g / 10 - 2000 Hz <i>60 g / 10 - 2000 Hz</i>
BEFESTIGUNGSDREHMOMENT <i>MOUNTING TORQUE</i>	---- Ncm <i>---- in.oz.</i>	STOSSBEANSPRUCHUNG <i>SHOCK</i>	1500 g / 0,5 ms <i>1500 g / 0.5 ms</i>
EINSTELLGENAUIGKEIT <i>ADJUSTMENT ACCURACY</i>	≤ 1 x10 <sup>-3</sup> vom Einstellwert <i>≤ 1 x10<sup>-3</sup> of adjusted value</i>	BETRIEBSTEMPERATUR <i>OPERATING TEMPERATURE</i>	-65°C ... +125°C <i>-65°C ... +125°C</i>
KONTAKTWIDERSTAND <i>CONTACT RESISTANCE</i>	< 0,001 Ω <i>&lt; 0.001 W</i>	DIELEKTRIKUM <i>DIELECTRIC</i>	Luft (Luftspalt 0,1mm) <i>Air (Air gap 0,1mm)</i>

Teile - Nr. <i>Part - No.</i>	C <sub>min</sub> [pF]	C <sub>max</sub> [pF]	Prüfspannung <i>Test Voltage</i> [VDC]	Q-Faktor <i>Q-Factor</i> [@ 200MHz]	R <sub>isol.</sub> <i>R<sub>insul.</sub></i> [MΩ]	TK <sub>c</sub> [ppm/°C]	Maß A <i>Dim.A</i> [mm]	Maß B <i>Dim.B</i> [mm]	Gewicht <i>Weight</i> [ca. g]
60-0422-10005-903	0,5	5,0	250	> 5000	> 10 <sup>6</sup>	50 ± 15	---	---	1,0

### SONDERANFERTIGUNG / *SPECIAL CONFIGURATION*

Trimmer mit Hochtemperaturlot (Schmelzbereich 320 / 350°C) verlötet.  
*Trimmer soldered with high temperature solder (melting range 320 / 350°C).*