



TRONSER TRIMMER

for
professional
electronics

60-0420-10003-600

LUFTROHRTRIMMER
AIR TUBULAR TRIMMER

DATUM / DATE : 05.07.2000
ÄNDERUNG / REVISION :
KUNDE / CUSTOMER :

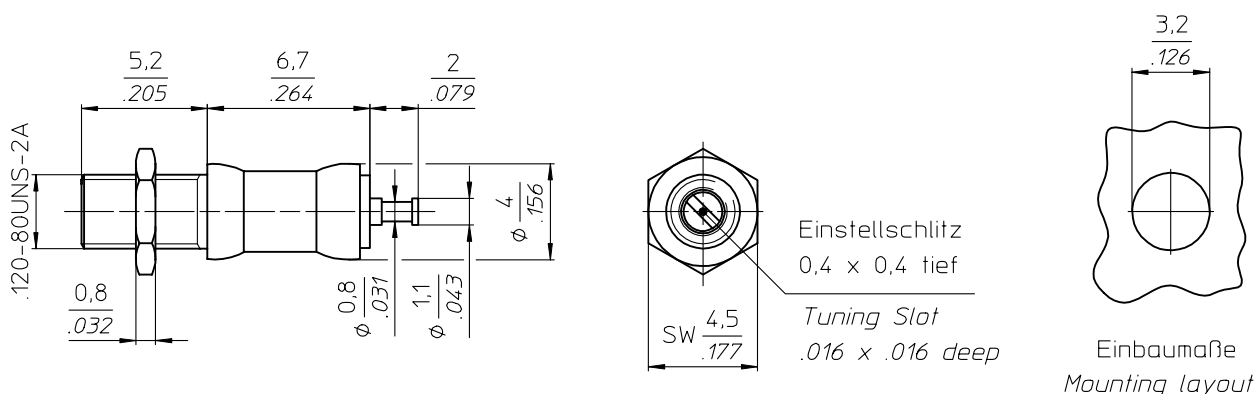

TECHNISCHE MERKMALE UND DATEN / TECHNICAL DATA

EINSTELLDREHMOMENT <i>TUNING TORQUE</i>	0,2 - 2,0 Ncm <i>0.3 - 2.8 in.oz.</i>	LEBENSDAUER <i>ROTATIONAL LIFE</i>	≥ 75 Betätigungen, IEC 418 <i>≥ 75 cycles, IEC 418</i>
ANSCHLAGDREHMOMENT <i>STOP TORQUE</i>	max. 2,5 Ncm <i>max. 3.4 in.oz.</i>	VIBRATION <i>VIBRATION</i>	60 g / 10 - 2000 Hz <i>60 g / 10 - 2000 Hz</i>
BEFESTIGUNGSDREHMOMENT <i>MOUNTING TORQUE</i>	max. 10 Ncm <i>max. 13.8 in.oz.</i>	STOSSBEANSPRUCHUNG <i>SHOCK</i>	1500 g / 0,5 ms <i>1500 g / 0.5 ms</i>
EINSTELLGENAUIGKEIT <i>ADJUSTMENT ACCURACY</i>	≤ 1 x 10 ⁻³ vom Einstellwert <i>≤ 1 x 10⁻³ of adjusted value</i>	BETRIEBSTEMPERATUR <i>OPERATING TEMPERATURE</i>	-65°C ... +125°C <i>-65°C ... +125°C</i>
KONTAKTWIDERSTAND <i>CONTACT RESISTANCE</i>	< 0,001 Ω <i>< 0.001 Ω</i>	DIELEKTRIKUM <i>DIELECTRIC</i>	Luft (Luftspalt 0,1 mm) <i>Air (Air gap 0,1mm)</i>

Teile - Nr. <i>Part - No.</i>	C _{min} [pF]	C _{max} [pF]	Prüfspannung <i>Test Voltage</i> [VDC]	Q-Faktor <i>Q-Factor</i> [@ 200MHz]	R _{isol.} <i>R_{insul.}</i> [MΩ]	TK _c [ppm / °C]	Maß A <i>Dim.A</i> [mm]	Maß B <i>Dim.B</i> [mm]	Gewicht <i>Weight</i> [ca. g]
60-0420-10003-600	0,3	3,5	250	> 5000	> 10 ⁶	50 ± 15	---	---	1,0

Die Verwendung von Hochtemperaturlot erlaubt Lötbadtemperaturen beim Einbau in gedruckte Schaltungen bis +300°C.
Lötdauer max. 10 s.
Use of high temperature solder allows soldering temperature of +300°C for max. 10 s.

SONDERANFERTIGUNG / SPECIAL CONFIGURATION

Trimmer unmagnetisch (Permeabilität < 1,001)
Trimmer non-magnetic (permeability < 1,001)