



TRONSER TRIMMER

for
professional
electronics

DATUM / DATE : 10.12.2001
ÄNDERUNG / REVISION : 13.12.2005

10-1708-50...-000 LUFTPLATTENTRIMMER AIRPLATE TRIMMER

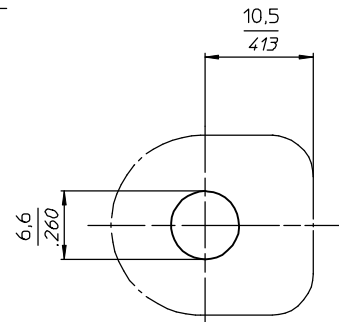
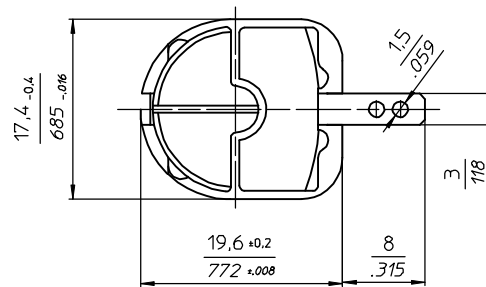
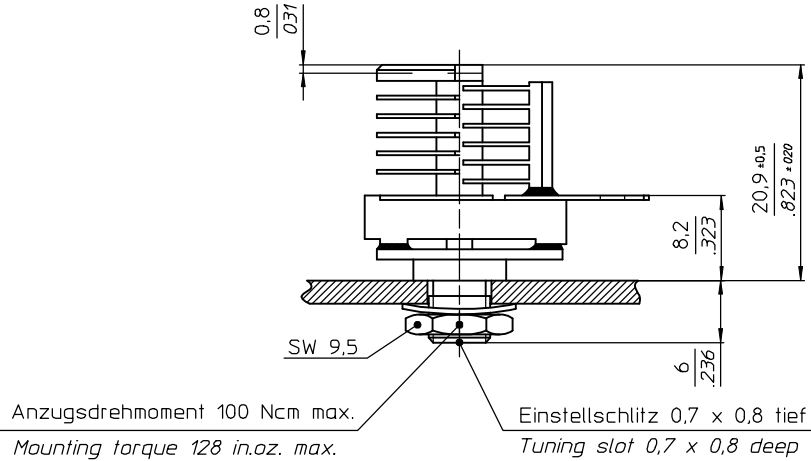

TECHNISCHE MERKMALE UND DATEN / TECHNICAL DATA

EINSTELLDREHMOMENT TUNING TORQUE	2,5 - 5,0 Ncm 3.5 - 7.0 in.oz.	KERAMIK CERAMIC	DIN 40685 / 221 , silikonisiert DIN 40685 / 221 , siliconized
Q-FAKTOR Q-FACTOR	> 5000 bei 1 MHz > 5000 @ 1 MHz	DIELEKTRIKUM DIELECTRIC	Luft Air
BETRIEBSTEMPERATUR OPERATING TEMPERATURE	-65°C ... +125°C -65°C ... +125°C		

STANDARD - AUSFÜHRUNGEN / STANDARD CONFIGURATIONS

Teile - Nr. Part - No.	C _{min} [pF]	C _{max} [pF]	Plattenzahl No.Of Plates Stator / Rotor	Luftspalt Air Gap [mm]	Prüfspannung Test Voltage [-V _{eff}]	R _{isol.} R _{insul.} [MΩ]	TK _c [ppm / °C]	Höhe h Height h [mm]	Gewicht Weight [ca. g]
10-1708-50005-000	2,5	6,0	2 / 2	0,50	1000	> 10 ³	45 ± 20	13,5	10,3
10-1708-50012-000	3,0	12,5	4 / 4	0,50	1000	> 10 ³	45 ± 20	17,1	12,0
10-1708-50019-000	3,7	19,5	6 / 6	0,50	1000	> 10 ³	45 ± 20	20,7	13,5
10-1708-50025-000	4,4	26,0	8 / 8	0,50	1000	> 10 ³	45 ± 20	24,3	15,0

SONDERAUSFÜHRUNGEN / SPECIAL CONFIGURATIONS

auf Anfrage
on inquiry